

Reference:

Client:

Project:

Consultant:

Location:

Contractor:

Date:

Submitted by:



Manufacturing Excellence

Model FD-MB-3V(M)

Motorised Static Fire Damper

Multi-Blade, 3V Blade

1-1/2 or 3 Hour, UL555 Classified

Application:

The CVS-SAFE4 model FD-MB-3V(M) is a motorised multi-blade fire damper with 3V blades. The FD-MB-3V(M) is used to prevent the spread of fire through a penetration in a fire rated barrier made by an HVAC duct or transfer. The FD-MB-3V(M) can be installed vertically (with blades running horizontally) or horizontally. The FD-MB-3V(M) can be installed in static systems (fans shut off in a fire) only. This model is most commonly used when required sizes exceed CVS's UL listing for the CVS Model FD (curtain style fire damper). Refer to the Maximum and Minimum Size table on this page.



LISTINGS:

UL 555 Listing: R27700(UAE), R41135(KSA), R40068(Qatar), R41122(Egypt)

STANDARDS MET:

NFPA Standards: 80, 90A, 92A, 92B and 101

Building Code Standard:

ICC International Building Code

Standard Construction:

	Standard	Optional
Frame Material	20 Gauge (1) Galv. Roll-Formed Steel hat section w/ staked corners for integral bracing	-----
Blade Material and Type	16 Gauge (1.5) "3V" Galv. Roll-Formed Steel	Airfoil Galv. Steel (see Model FD-MB-AF(M))
Blade Sizes	Min. width of 4.25" (108) to max. width of 7.25" (184)	-----
Frame Depth	5" (127)	-----
Dimensions	Actual - 1/4" (6)	Actual
Axle Bearings	Bronze Oilite (press fit into frame)	-----
Axle Material	Square, Plated Steel	-----
Linkage	.125" (3.2) plated steel, Concealed in Frame	-----
Side Plate	20 gauge side plate at one side only.	Wide variety of gauges and lengths available
Heat Responsive Device	Electric thermostat 165°F (74°C)	212° (100°C)
UL Hourly Fire Rating	1-1/2 Hour	3 Hour
Blade Operator	Motorised	Manual quadrant (see Model FD-MB-3V)

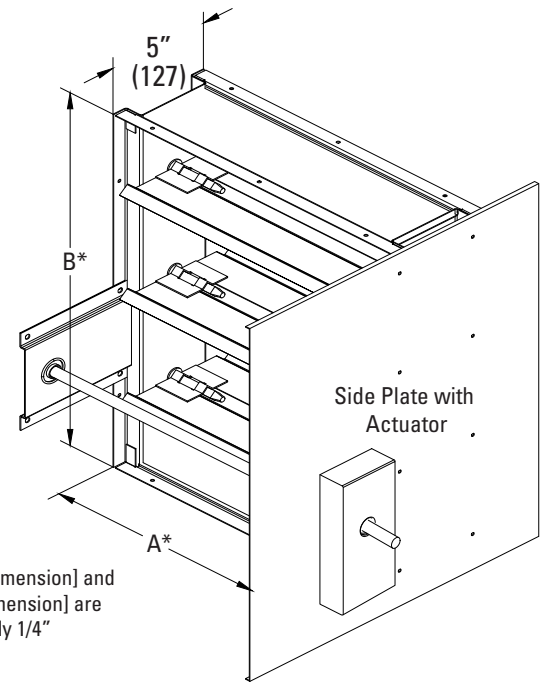

* Width [A dimension] and Height [B dimension] are approximately 1/4" (6) undercut.

Optional Construction:

Factory Installed Sleeve

Gauge: 20 (1.0) 18 (1.2) 16 (1.5) 14 (2.0) 10 (3.5)

Length: _____

Flanged sleeve (requires factory installed external sleeve)

3/4" (19) 1" (25)

Framed Retaining Angles: 16ga. x 1-1/2 x 1-1/2 (1.5 x 38 x 38)

Single Side Dual Side

Actuators (Refer to UL Damper Actuator Reference Chart)

Type: Electric: Model # _____ Pneumatic: Model # _____

Location: Right External (Std) Left External Internal

Other Options:

- Dynamic models (see Model FDD-MB-3V(M))
- Out-of-Wall models (see Model FD-OW)
- True Round models (see Model FD-RD)

Minimum & Maximum Sizes:

Multi-Blade Model	Minimum Size		Max. Single Section		Max. Multi-Section	
	1.5 Hour	3 Hour	1.5 Hour	3 Hour	1.5 Hour	3 Hour
FD-MB-3V(M) (Vertical)	6x6 (152x152)		36x48 (914x1219)		108x96 (2743x2438)	72x48 (1829x1219)
FD-MB-3V(M) (Horizontal)					72x48 (1829x1219)	72x48 (1829x1219)

All dimensions shown in inches, parentheses () indicate millimeters.

Consult CVS for Other Special Requirements.

1 As part of our continuous improvement program, we reserve the right to make further improvements without notice.

Submittal

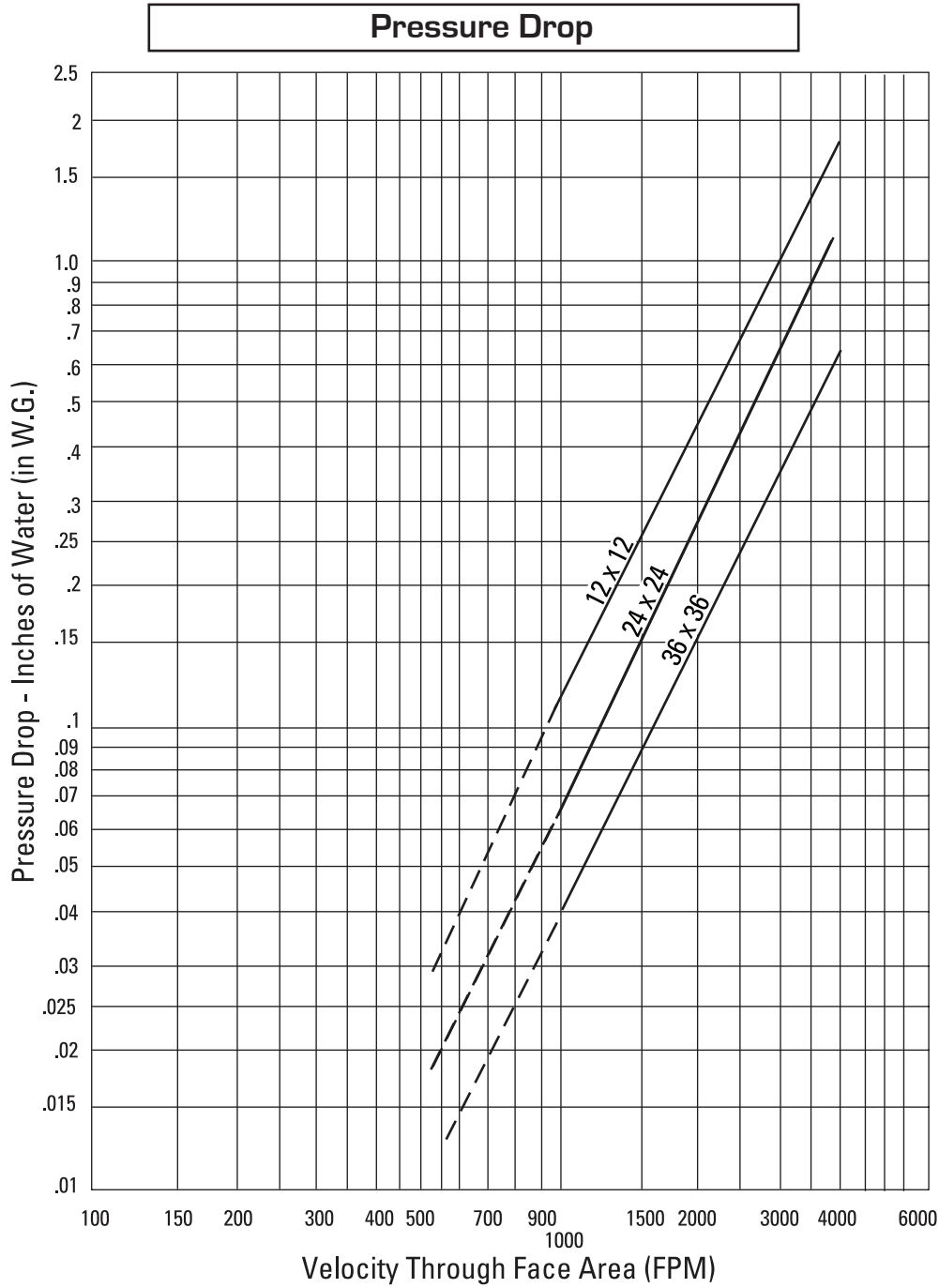

- To determine pressure drop:**
1. Locate the applicable face velocity on the bottom of the chart.
 2. Move up the chart to the most appropriate size damper line.
 3. From the intersection point, move left to determine the pressure drop.

AMCA Figure 5.3 - Ducted Inlet and Outlet

Pressure drop testing was performed by an independent laboratory to the AMCA Standard 500-D, Fig. 5.3 (ductwork upstream and downstream).

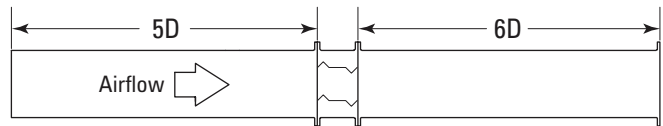

Sleeve Requirements:

Standard suggested sleeve depth is 16" (406), which is appropriate for use with up to a 6" deep (152) wall/floor and 2-sided mounting angle installation. (See Detail to the right).

When wall/floor thickness exceeds 6" (152), **add 1" (25) for each additional inch of wall/floor thickness** to ensure sleeve fully penetrates the wall/floor. Each additional 1" (25) added will be added to the non-actuator side.

The damper may be installed/rotated 180° as long as the blades run horizontally.

The top of the damper is either side of the frame as long as the blades are running horizontally.

Damper is not approved for installation with the blades running vertically.

The entire damper frame does not have to be installed in the plane of the wall/floor.

The requirement is that the blade closure line (the center line of the 5"(127) damper frame) must be within the plane of the fire-rated wall/floor.

Typical Sleeve Lengths

Wall Thickness	Min. Sleeve Length
6 (152)	16 (406)
8 (203)	18 (457)
12 (305)	22 (559)
16 (406)	24 (610)

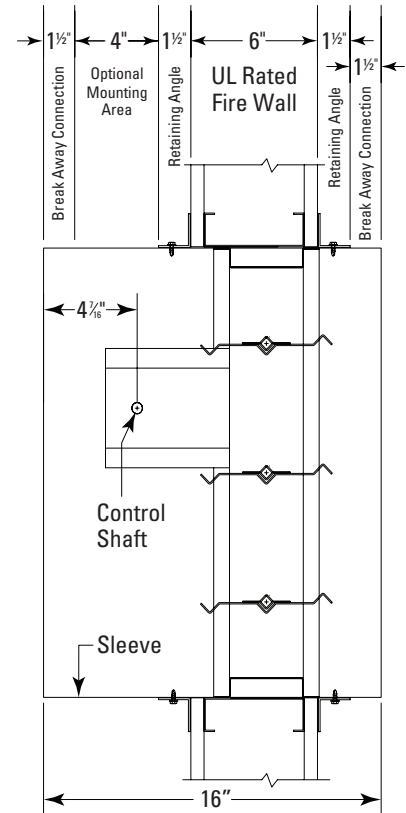

Sleeve Detail for Factory Mounted Sleeve

Duct Connections/Sleeve Transitions:

FD-MB-3V(M)

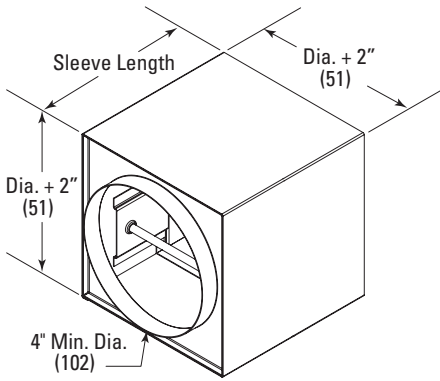

Square to Round transitions external on both ends of the damper sleeve. Product is ordered on duct Diameter; damper will be fabricated 2" (51) larger in width and height. Collar extends 1.25" (32) beyond the sleeve length.

- **Minimum 4" (102) diameter, Maximum 94" (2388) diameter for Vertical and Horizontal mount 1.5 Hour, 46" (1168) for Vertical and Horizontal 3 Hour.**

FD-MB-3V(M)

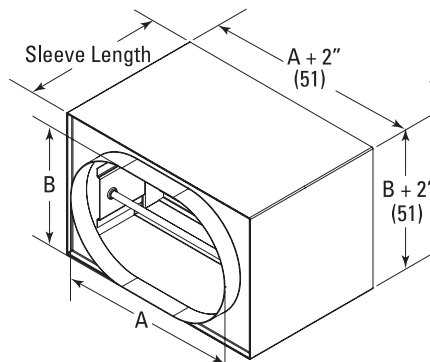

FD-MB-3V(M)

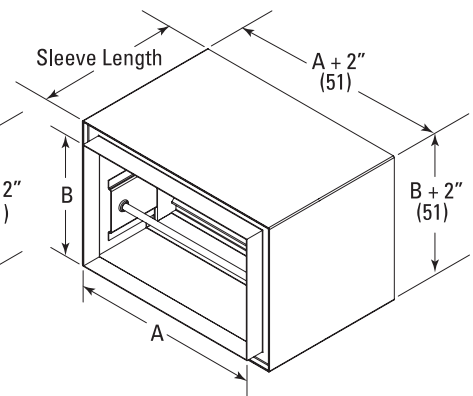

Rectangular to Oval or Square/Rectangular to Square/Rectangular transitions external on both ends of the damper sleeve. Product is ordered on width and height of duct connection required; damper will be fabricated 2" (51) larger in width and height. Collar extends 1.25" (32) beyond the sleeve length.

- **Minimum 4" w x 4" h (102 x 102), Maximum 106" w x 94" h (2692 x 2388) for Vertical 1.5 Hour mount, 34" w x 46" h (864 x 1168) for Horizontal 1.5 Hour mount and 70" w x 46" h (1778 x 1168) for Vertical or Horizontal 3 Hour mount.**

A= Duct Width
B= Duct Height