

Reference:

Client:

Project:

Contractor:

Location:

Contractor:

Date:

Submitted by:



Model FD-RD
True Round Static Fire Damper
1-1/2 Hour, UL555 Classified

Application:

The CVS-SAFE4 model FD-RD are True Round fire dampers. The FD-RD is used to prevent the spread of fire through a penetration in a fire rated barrier made by an HVAC duct or transfer. The FD-RD can be installed vertically or horizontally. The FD-RD can be installed in static systems (fans turn off in a fire) only. The FD-RD is only available with a 1-1/2 hour UL555 fire rating for installation in walls/floors with less than a 3 hour fire rating.

Note: Selecting a square fire damper with round transitions is a more economical solution and usually easier to install in the field.

Standard Construction:

	Standard	Optional
Frame Material	20 Gauge (1) Galvanized Steel Integral Steel	-----
Blade Material	Double Thickness Galvanized Steel, equivalent to 18-gauge with welded channel reinforcement	-----
Frame Depth	16" (406)	20" (508) or 24" (610)
Dimensions	Actual - 1/8" (3)	Actual
Axle Bearings	Bronze Oilite (press fit into frame)	-----
Axle Material	3/8" (10) Square, Plated Steel	-----
Jackshaft	1/2" (13) Dia. plated steel	-----
Linkage	Jackshaft to blade	-----
Spring	Stainless Steel Coil	-----
Retaining Plates	Two 20 Gauge (1) galvanized steel completed w/ angle clips	-----
Heat Responsive Device	UL Listed Fusible Link 165°F (74°C)	UL Listed Fusible Link 212°F (100°C)
UL Hour Rating	1-1/2 Hour	-----

Minimum & Maximum Sizes:

True Round Model	Minimum Size	Maximum Size
	1.5 Hour	1.5 Hour
FD-RD (Vertical)	8" Dia. (203)	24" Dia. (610)
FD-RD (Horizontal)		

All dimensions shown in inches, parentheses () indicate millimeters.

Optional Construction:

Factory Installed Integral Sleeve:

Length: 16"(406) Standard 20"(508) 24"(610)



LISTINGS:

UL 555 Listing: R27700(UAE), R41135(KSA), R40068(Qatar), R41122(Egypt)



STANDARDS MET:

NFPA Standards: 80, 90A, 92A, 92B and 101

Building Code Standard:

ICC International Building Codes

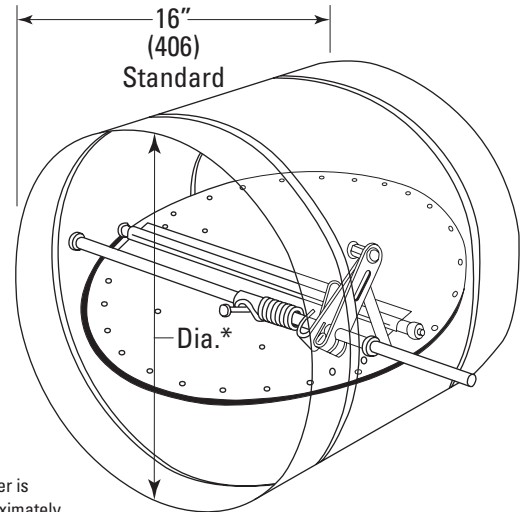

Damper Diameter is furnished approximately 1/8" (3) undercut.

Included Hardware & Mounting Accessories

Manual Hand Quadrant
(Representative Drawing)

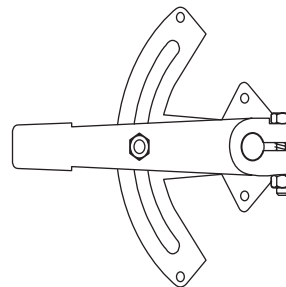

Note: Retaining plate on Operator Side of Damper is installed at the factory.

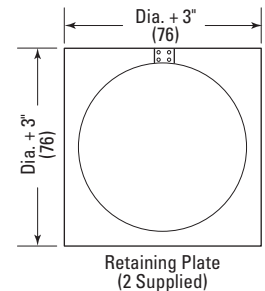

Retaining Plate (2 Supplied)

Other Option:

Square fire dampers w/round transitions (see FD Submittal)

Consult CVS for other Special Requirements

1 As part of our continuous improvement program, we reserve the right to make further improvements without notice.

Submittal

Pressure Drop

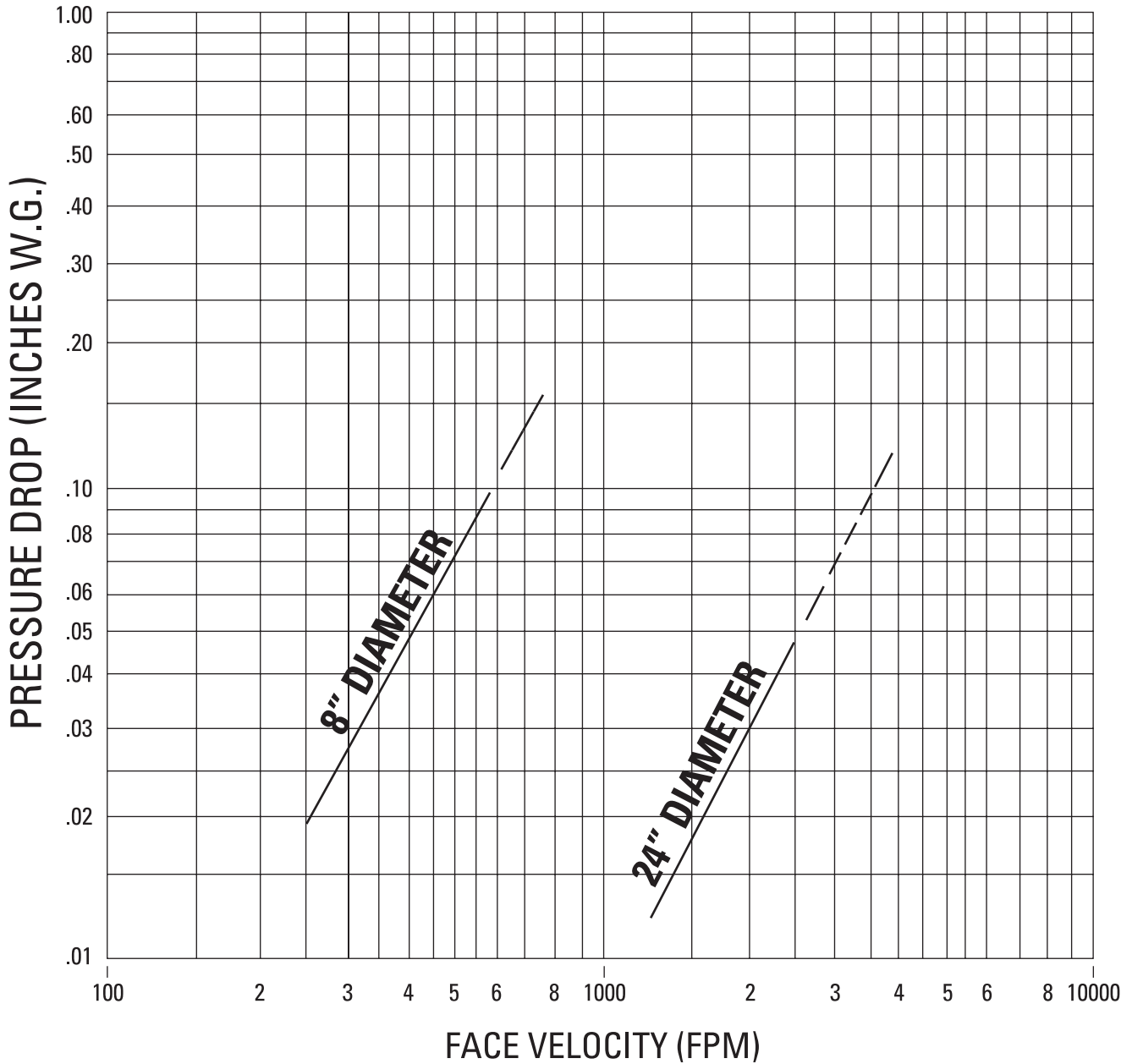

- To determine pressure drop:**
1. Locate the applicable face velocity on the bottom of the chart.
 2. Move up the chart to the most appropriate size damper line.
 3. From the intersection point, move left to determine the pressure drop.

AMCA Figure 5.3 - Ducted Inlet and Outlet

Pressure drop testing was performed by an independent laboratory to the AMCA Standard 500-D, Fig. 5.3 (ductwork upstream and downstream).

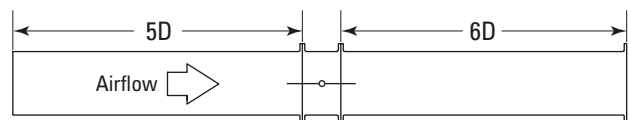

Sleeve Requirements:

Standard sleeve depth is 16" (406), which is appropriate for use with up to a 5" deep (127) wall/floor and 2-sided mounting angle installation. (See Detail to the right).

When the wall/floor thickness exceeds 5" (127), the FD-RD can be ordered with an integral sleeve of 20" (508) or 24" (610) to accommodate the thicker wall/floor.

The actuator is always externally installed on the right-hand of the damper when viewed from the jackshaft side. **The damper may be installed/rotated 180°** such that the actuator will be located on the left hand side.

The blade closure line must be within the plane of the fire-rated wall/floor.

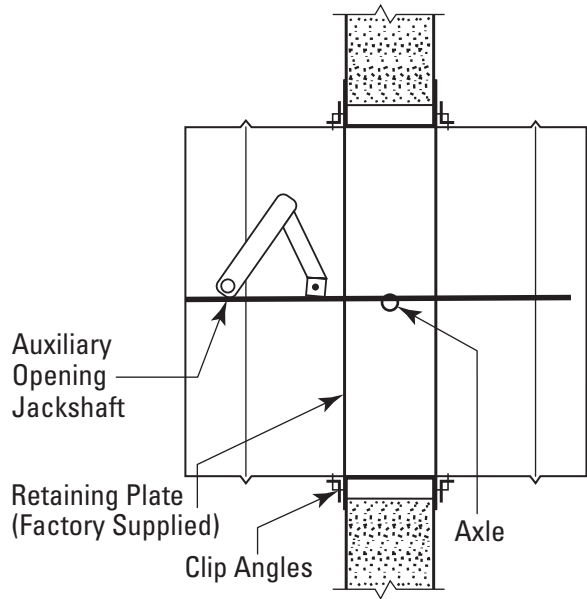

Clearance Requirements

