

Reference: Client:
 Project: Consultant:
 Location: Contractor:
 Date: Submitted by:



Model FSD-RD-211

True Round Combination
Fire/Smoke Damper

True Round, 1-1/2 Hour, Class 1, UL-Classified

(Class I is < 8 cfm per sq. ft. @ 4" w.g.)

Application:

The CVS-SAFE4 model FSD-RD-211 is a true round combination fire/smoke damper. The FSD-RD-211 is used to prevent the spread of fire and smoke through a penetration in a fire and smoke rated barrier made by an HVAC duct or transfer. The FSD-RD-211 can be installed vertically or horizontally. The FSD-RD-211 can be installed in static or dynamic systems up to the allowable tested pressures and velocities below.

MAXIMUM VELOCITY: 2000 fpm (10.2 m/s)

MAXIMUM PRESSURE: 4" wg (1kPa)

Standard Construction:

| | Standard | Optional |
|------------------------|---|---|
| Frame Material | 20-gauge (1) Galvanized Steel Integral Sleeve | ----- |
| Blade Material | Double Thickness Galvanized Steel, equivalent to 18-gauge with welded channel reinforcement | ----- |
| Frame Depth | 16" (406) | 20" (508) or 24" (610) |
| Dimensions | Actual - 1/8" (3) | Actual |
| Axle Bearings | Bronze Oilite (press fit into frame) | ----- |
| Axle Material | 3/8" (10) Square, Plated Steel | ----- |
| Jackshaft | 1/2" (13) Dia. plated steel | ----- |
| Seals | Pressure Sensitive 450°F (232°C) sandwiched between blades | ----- |
| Linkage | Jackshaft to blade | ----- |
| Retaining Plates | Two 20 Gauge (1) galvanized steel completed w/ angle clips | ----- |
| Heat Responsive Device | Electric thermostat (165°F - 74°C) | 212°F (100°C) 250°F (121°C) 350°F (177°C) |
| Operating Temp. | 350° (177°C) | ----- |
| Leakage Class Rating | Class 1 | Class 2 (see Model FSD-RD-212) |
| UL Hour Rating | 1-1/2 Hour | ----- |

All dimensions shown in inches, parentheses () indicate millimeters.

Minimum & Maximum Sizes:

| True Round Model | Minimum Size | | Maximum Size | |
|-------------------------|---------------|--|----------------|--|
| | 1.5 Hour | | 1.5 Hour | |
| FSD-RD-211 (Vertical) | 8" Dia. (203) | | 24" Dia. (610) | |
| FSD-RD-211 (Horizontal) | | | | |

All dimensions shown in inches, parentheses () indicate millimeters.



LISTINGS:

UL Listing: R27700(UAE), R41135(KSA), R40068(Qatar), R41122(Egypt)



STANDARDS MET:

NFPA Standards: 80, 90A, 92A, 92B and 101

Building Code Standard:

ICC International Building Code

*Damper Diameter is furnished approximately 1/8" (3) undercut.

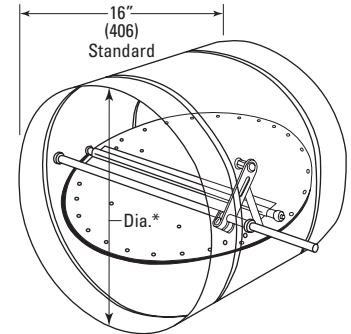

Included Hardware & Mounting Accessories:

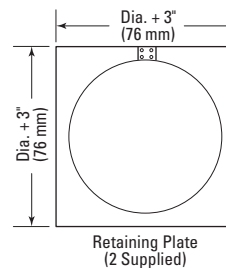

Retaining Plate (2 Supplied)

Note: Retaining plate on Operator Side of Damper is installed at the factory.

Optional Construction:

Auxiliary Switch

Add to Actuator (recommended) Add to Damper (STO/R)

Momentary Test Switch

DTO/R Thermostat Override w/ Dual Position Indicator Switches

Temp: 165°/250° 165°/350° 212°/350°

Factory Integral Sleeve:

Length: 16" (406) Standard 20" (508) 24" (610)

Remote Control Box

RCB-1 RCB-2 RCB-3

Smoke Detector (Shipped Loose)

Actuators (Refer to UL Damper Actuator Reference Chart)

Type: Electric: Model # _____ Pneumatic: Model # _____

Location: Right External (Std) Left External Internal

Pressure Drop

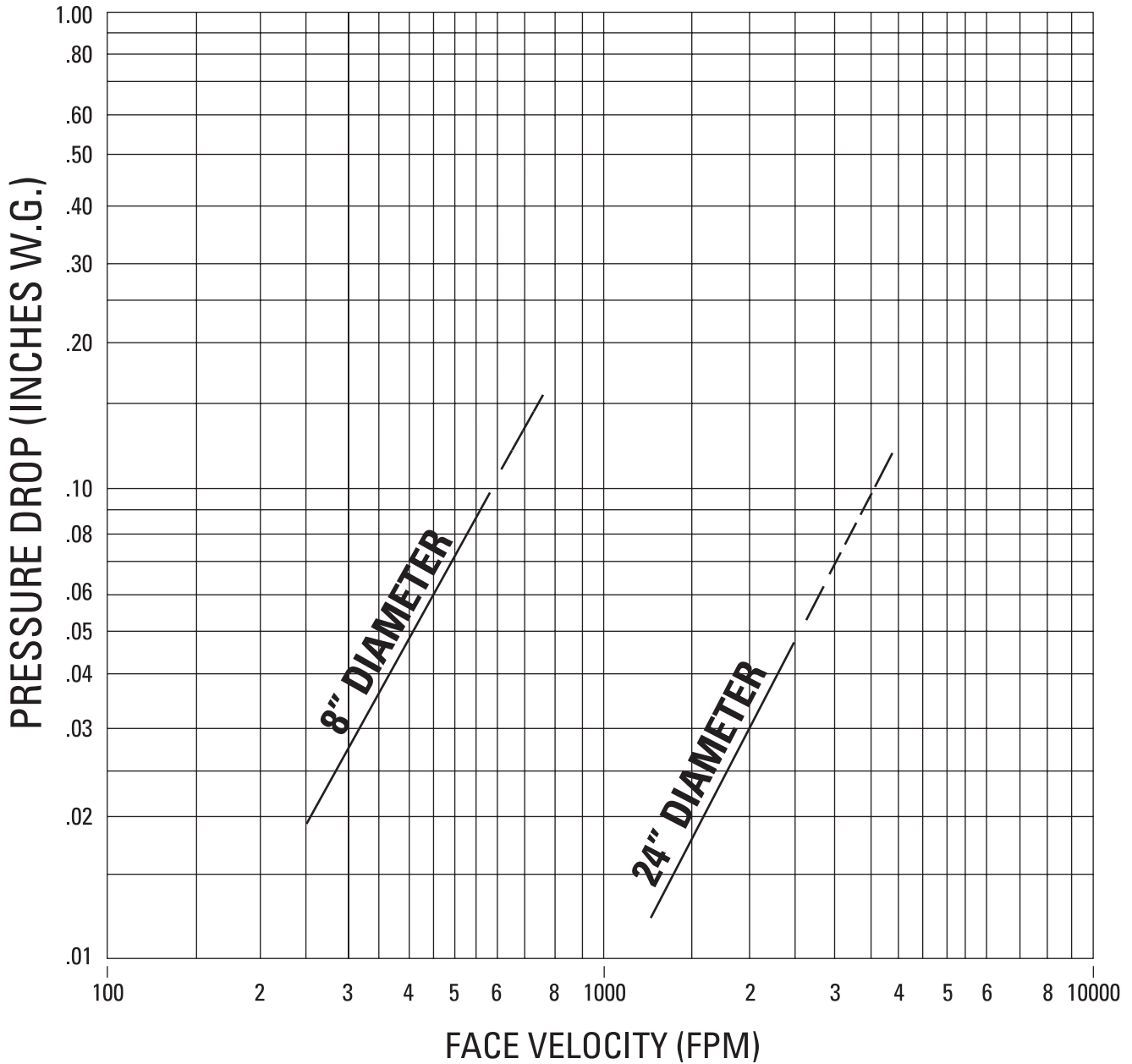

- To determine pressure drop:**
1. Locate the applicable face velocity on the bottom of the chart.
 2. Move up the chart to the most appropriate size damper line.
 3. From the intersection point, move left to determine the pressure drop.

AMCA Figure 5.3 - Ducted Inlet and Outlet

Pressure drop testing was performed by an independent laboratory to the AMCA Standard 500-D, Fig. 5.3 (ductwork upstream and downstream).

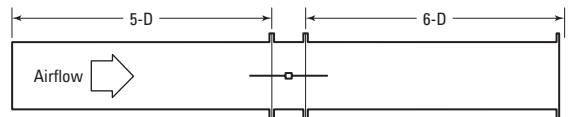

Actuator Requirements:

UL555S requires that all leakage rated dampers be provided with factory mounted actuators. Available actuators vary by damper size and velocity, pressure and temperature ratings. Consult Motor/Actuator sheet for UL Products for current offering.

All electric actuators will be factory wired to a single heat-responsive device. *The default heat-responsive device is a resettable thermostat that interrupts power to the actuator allowing for controlled closure.*

If pneumatic actuators are employed, the actuator will be plumbed to a PFV (Pneumatic Fusible Valve). The PFV is used in conjunction with a restrictor valve to also provide controlled closure.

Sleeve Requirements:

Standard sleeve depth is 16" (406), which is appropriate for use with up to a 5" deep (127) wall/floor and 2-sided mounting angle installation. (See Detail to the right).

When the wall/floor thickness exceeds 5" (127), the FSD-RD-211 can be ordered with an integral sleeve of 20" (508) or 24" (610) to accommodate the thicker wall/floor.

The actuator is always externally installed on the right-hand of the damper when viewed from the jackshaft side. **The damper may be installed/rotated 180°** such that the actuator will be located on the left hand side.

The blade closure line must be within the plane of the fire-rated wall/floor.

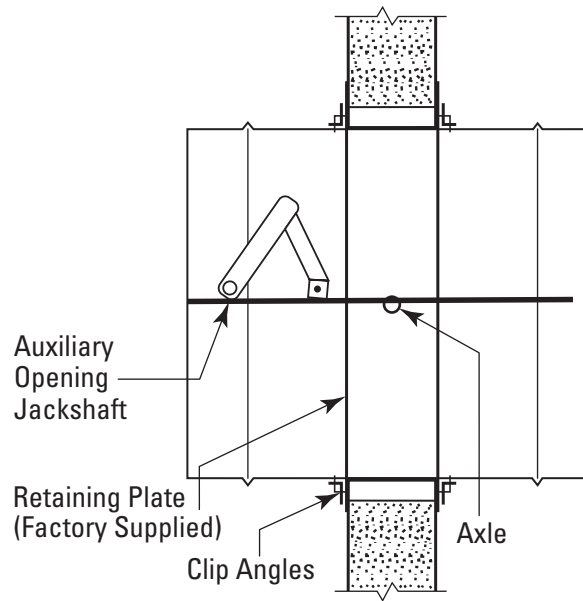

Clearance Requirements

