

Reference: Client:  
 Project: Consultant:  
 Location: Contractor:  
 Date: Submitted by:



Manufacturing Excellence

**Model FSD-3V-CR-211**  
 Combination Fire/Smoke Corridor Damper  
 3V Blade, 1-1/2 Hour, Class 1, UL-Classified  
 (Class I is < 8 cfm per sq. ft. @ 4" w.g.)

**Application:**

The CVS-SAFE4 model FSD-3V-CR-211 is a combination fire/smoke Corridor Damper with 3V style blades. The FSD-3V-CR-211 is used to prevent the spread of fire and smoke through a penetration in a fire and smoke rated corridor ceiling construction. The FSD-3V-CR-211 can be installed in static or dynamic systems up to the allowable tested pressures and velocities below.

**MAXIMUM VELOCITY:** 2000 fpm (10.2 m/s)

**MAXIMUM PRESSURE:** 4" wg (1kPa)

**Standard Construction:**

	Standard	Optional
<b>Frame Material</b>	20 Gauge (1) Galv. Roll-Formed Steel hat section w/ staked corners for integral bracing	-----
<b>Blade Material and Type</b>	16 Gauge (1.5) "3V" Galv. Roll-Formed Steel	-----
<b>Blade Sizes</b>	Min. width of 4.25" (108) to max. width of 7.25" (184)	-----
<b>Frame Depth</b>	5" (127)	-----
<b>Dimensions</b>	Actual - 1/4" (6)	Actual
<b>Axle Bearings</b>	Bronze Oilite (press fit into frame)	-----
<b>Axle Material</b>	Square, Plated Steel	-----
<b>Seals</b>	Pressure sensitive 450°F (232°C) silicone blade edge seals and flexible stainless jamb seals	-----
<b>Linkage</b>	.125" (3.2) plated steel, Concealed in Frame	-----
<b>Sleeve</b>	16" x 20 gauge (406x1) galvanized steel	Wide variety of gauges and lengths available
<b>Heat Responsive Device</b>	Electric thermostat 165°F (74°C)	212°F (100°C) 250°F (121°C) 350°F (177°C)
<b>Operating Temp.</b>	350° (121°C)	-----
<b>Leakage Class Rating</b>	Class 1	Class 2 (see Model FSD-3V-CR-212)
<b>UL Hour Rating</b>	1-1/2 Hour	3 Hour (see Model FSD-3V-231)

All dimensions shown in inches, parentheses ( ) indicate millimeters.

**Minimum & Maximum Sizes:**

Corridor Damper Model	Minimum Size	Maximum Size
<b>FSD-3V-CR-211 Horizontal</b>	8x8 (203 x203)	24x24 (610 x 610)

All dimensions shown in inches, parentheses ( ) indicate millimeters.



**LISTINGS:**

UL Listing: R27700(UAE), R41135(KSA), R40068(Qatar), R41122(Egypt)



**STANDARDS MET:**

**NFPA Standards:** 80, 90A, 92A, 92B and 101

**Building Code Standard:**

ICC International Building Code

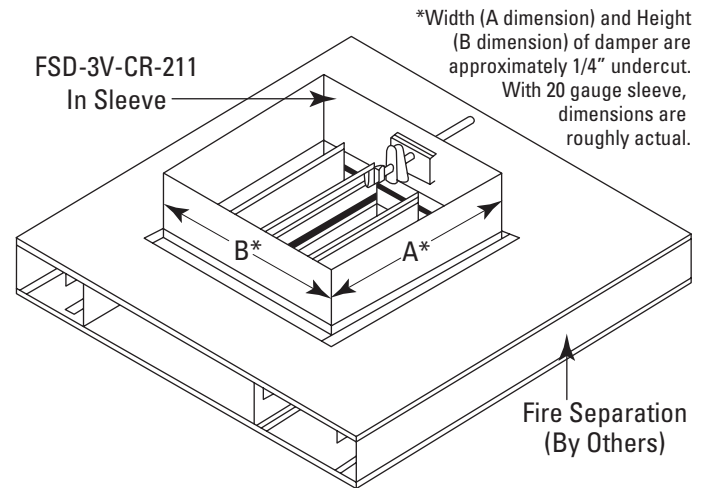

**Optional Construction:**

**Auxiliary Switch**

Add to Actuator (recommended) Add to Damper (STO/R)

**Momentary Test Switch**

**DTO/R Dual Thermostat Override w/ Dual Position Indicator Switches**

**Temp:** 165°/250° 165°/350° 212°/350°

**Factory Sleeve:**

**Length:** \_\_\_\_\_ (Std. 16" [406])

**Gauge:** 20 (1.0) 18 (1.2) 16 (1.5) 14 (2.0) 10 (3.5)

**Framed Retaining Angles (FRA)**

1-Side 2-Sides

**Remote Control Box**

RCB-1 RCB-2 RCB-3

**Smoke Detector**

Factory Mounted Shipped Loose

**Actuators** (Refer to UL Damper Actuator Reference Chart)

**Type:** Electric: Model # \_\_\_\_\_ Pneumatic: Model # \_\_\_\_\_

**Location:** Right External (Std) Left External Internal

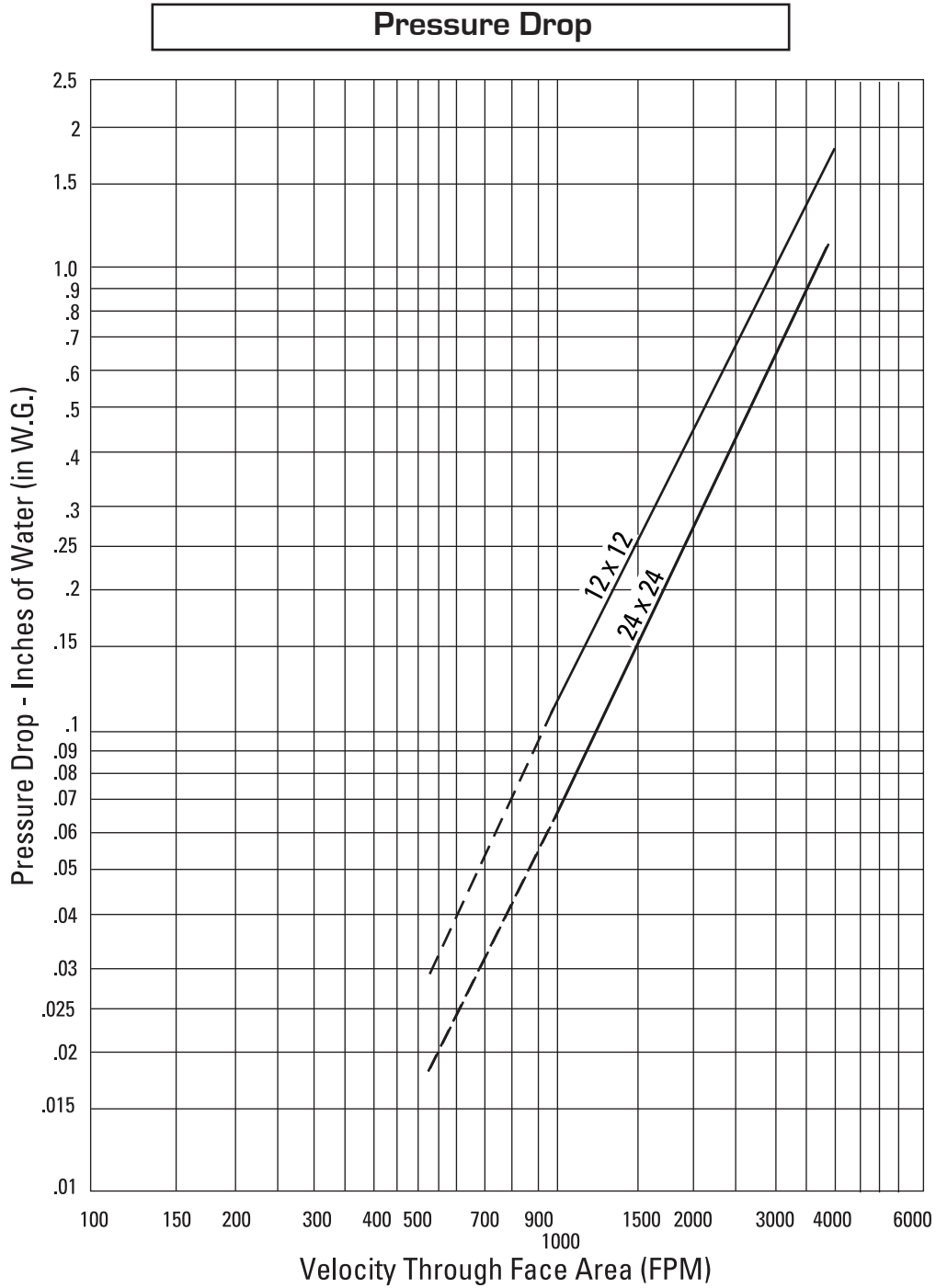

- To determine pressure drop:**
1. Locate the applicable face velocity on the bottom of the chart.
  2. Move up the chart to the most appropriate size damper line.
  3. From the intersection point, move left to determine the pressure drop.

**AMCA Figure 5.3 - Ducted Inlet and Outlet**

Pressure drop testing was performed by an independent laboratory to the AMCA Standard 500-D, Fig. 5.3 (ductwork upstream and downstream).

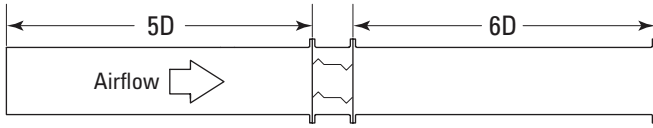

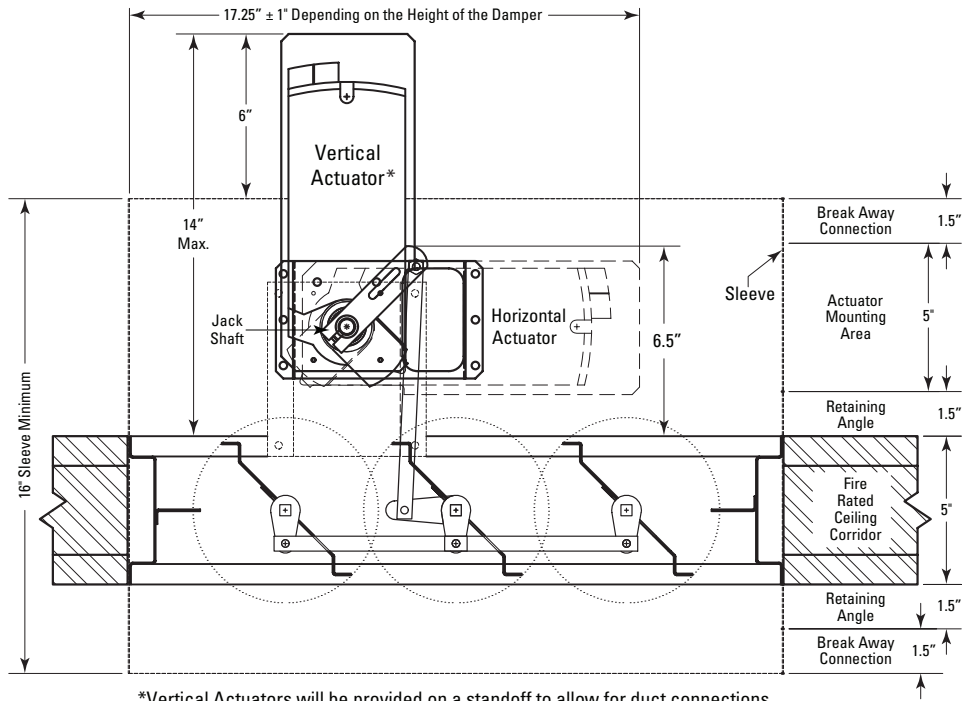

\*Vertical Actuators will be provided on a standoff to allow for duct connections.

### Actuator Requirements:

**UL555S requires that all leakage rated dampers be provided with factory mounted actuators.** Available actuators vary by damper size and velocity, pressure and temperature ratings. Consult Motor/Actuator sheet for UL Products for current offering.

All electric actuators will be factory wired to a single heat-responsive device. *The default heat-responsive device is a resettable thermostat that interrupts power to the actuator allowing for controlled closure.*

### Sleeve Requirements:

Standard sleeve depth is 16" (406), which is appropriate for use with up to a 5" deep (127) ceiling and 2-sided mounting angle installation. (See Detail above).

When the actuator is externally mounted and the ceiling thickness exceeds 5" (127), **add 1" (25) for each additional inch of ceiling thickness** to ensure sleeve fully penetrates the ceiling. Each additional 1" (25) added will be added to the non-actuator side.

As a standard, the actuator is externally installed on the lower right-hand half of the damper when viewed from the jackshaft side.

**The damper may be installed/rotated 180°** such that the actuator will be located on the upper left. The top of the damper is either side of the frame as long as the blades are running parallel.

**Damper is not approved for installation with the blades running vertically.**

**The entire damper frame does not have to be installed in the plane of the ceiling.** The requirement is that the blade closure line (the center line of the 5" (127) damper frame) must be within the plane of the fire-rated corridor ceiling.

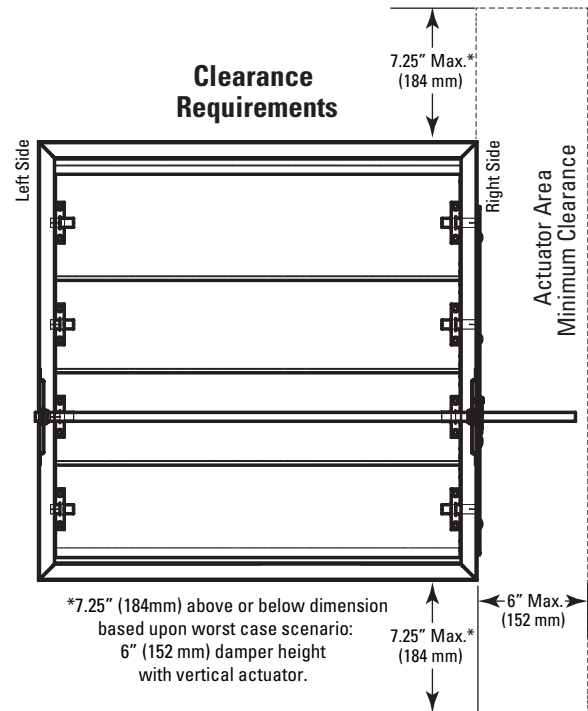

\*7.25" (184mm) above or below dimension based upon worst case scenario: 6" (152 mm) damper height with vertical actuator.

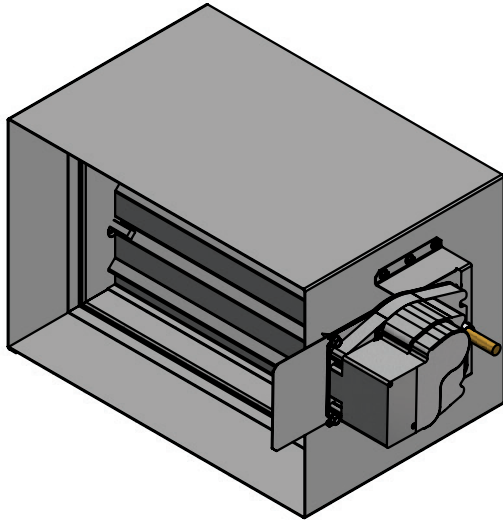

Standard Sleeve configuration where sleeve is added to damper. Damper size will be 1/4" (6) under ordered dimensions; sleeve dimension will be roughly ordered dimensions.

**Flanges:** An optional 3/4" (19) flanged sleeve is available for grille mounting.

**Note:** If actuator is to be externally mounted, the flange(s) will need to be field installed.

**Duct Connections/Sleeve Transitions:**

Minimum Damper height is 6" (152). If smaller duct heights are required, a transition will be supplied as shown in the detail FSD-3V-CR-211.

- **Minimum duct height for is 4" (102).**

Square to Round transitions attached on both ends of the damper sleeve (Model FSD-3V-CR-211). Product is ordered on duct Diameter; damper will be fabricated 2" (51) larger in width and height. Collar extends 1.25" (32) beyond the sleeve length.

- **Minimum 4" (102) diameter, Maximum 22" (559) diameter.**

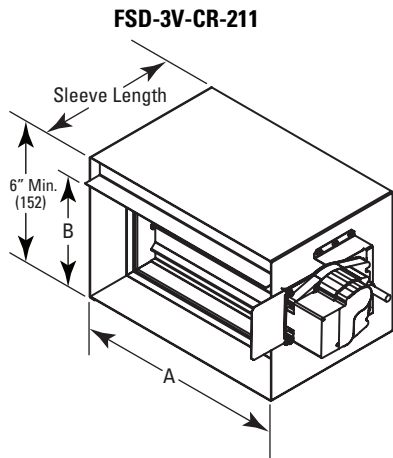

**A = Duct Width**  
**B = Duct Height**

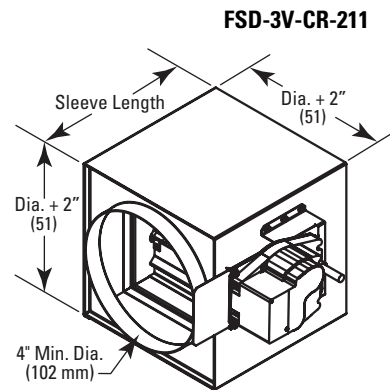

Rectangular to Oval (Model FSD-3V-CR-211) or Square/Rectangular to Square/Rectangular (Model FSD-3V-CR-211) transitions attached on both ends of the damper sleeve. Product is ordered on width and height of duct connection required; damper will be fabricated 2" (51) larger in width and height. Collar extends 1.25" (32) beyond the sleeve length.

- **Minimum 4" w x 4" h (102 x 102), Maximum 22" w x 22" h (559 x 559).**

