

Reference:

Client:

Project:

Consultant:

Location:

Contractor:

Date:

Submitted by:



Manufacturing Excellence

Model FDD-MB-AF-OW

Manual Quadrant Dynamic Fire Damper
Out-of-Wall/Floor Application
Multi Blade, Airfoil, 1-1/2, UL555 Classified

Application:

The CVS-SAFE4 model FDD-MB-AF-OW is a fire damper with Airfoil style blades, for decreased pressure drop, intended for installation outside the plane of a wall or floor. The FDD-MB-AF-OW is used to prevent the spread of fire through a penetration in a fire rated barrier made by an HVAC duct or transfer. The FDD-MB-AF-OW can be installed vertically (with blades running horizontally) or horizontally. The FDD-MB-AF-OW can be installed in static or dynamic systems up to the allowable tested pressures and velocities below.

MAXIMUM VELOCITY: 2000 fpm (10.2 m/s).

MAXIMUM PRESSURE: 4" wg (1kPa).

Standard Construction:

	Standard	Optional
Frame Material	20 Gauge (1) Galv. Roll-Formed Steel hat section w/ staked corners for integral bracing	-----
Blade Material and Type	Airfoil-shaped, double skin galvanized steel mechanically fastened to form equivalent to 14 Gauge (2) Steel	16 Gauge (1.5) "3V" Galvanized Roll-Formed Steel (see Model FDD-MB-3V-OW)
Blade Sizes	Min. width of 5" (127) to max. width of 7.25" (178)	-----
Frame Depth	5" (127)	-----
Dimensions	Actual - 1/4" (6)	Actual
Axle Bearings	Bronze Oilite (press fit into frame)	-----
Axle Material	Plated Steel	-----
Linkage	.125" (3.2) plated steel, Concealed in Frame	-----
Sleeve	16" x 20 gauge (406x1) galvanized steel	Wide variety of gauges and lengths available
Thermal Blanket	0.25" (6) thick thermal blanket 3 sides for vertical & 4 sides for horizontal applications	-----
Heat Responsive Device	UL Listed Fusible Link 165°F (74°C)	UL Listed Fusible Link 212°F (100°C)
Blade Operator	Manual Quadrant	Motorised [see Model FDD-MB-AF-OW (M)]
UL Hour Rating	1-1/2 Hour	3 Hours

All dimensions shown in inches, parentheses () indicate millimeters.

Minimum & Maximum Sizes:

Out of Wall Mounting	Minimum Size	Maximum Size
	1.5 Hour	1.5 Hour
FDD-MB-AF-OW Horizontal & Vertical	6 x 6 (152 x 152)	36 x 48 (914 x 1219)

All dimensions shown in inches, parentheses () indicate millimeters.



LISTINGS:

UL 555 Listing: R27700(UAE), R41135(KSA), R40068(Qatar), R41122(Egypt)

STANDARDS MET:

NFPA Standards: 80, 90A, 92A, 92B and 101

Building Code Standard:

ICC International Building Code

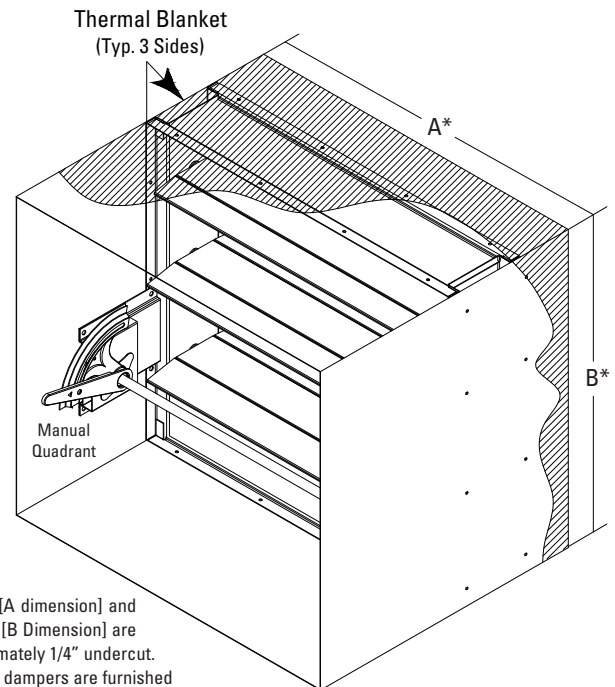

*Width [A dimension] and *Height [B Dimension] are approximately 1/4" undercut. Sleeved dampers are furnished approximately same size as given duct dimension plus 0.25" (6) for insulation.

Optional Construction:

Factory Installed Sleeve:

Length: _____ (Std. 16" [406])

Gauge: 20 (1.0) 18 (1.2) 16 (1.5) 14 (2.0) 10 (3.5)

Framed Retaining Angles (FRA)

1-Side 2-Sides

Remote Control Box

RCB-1 RCB-2 RCB-3

Pressure Drop

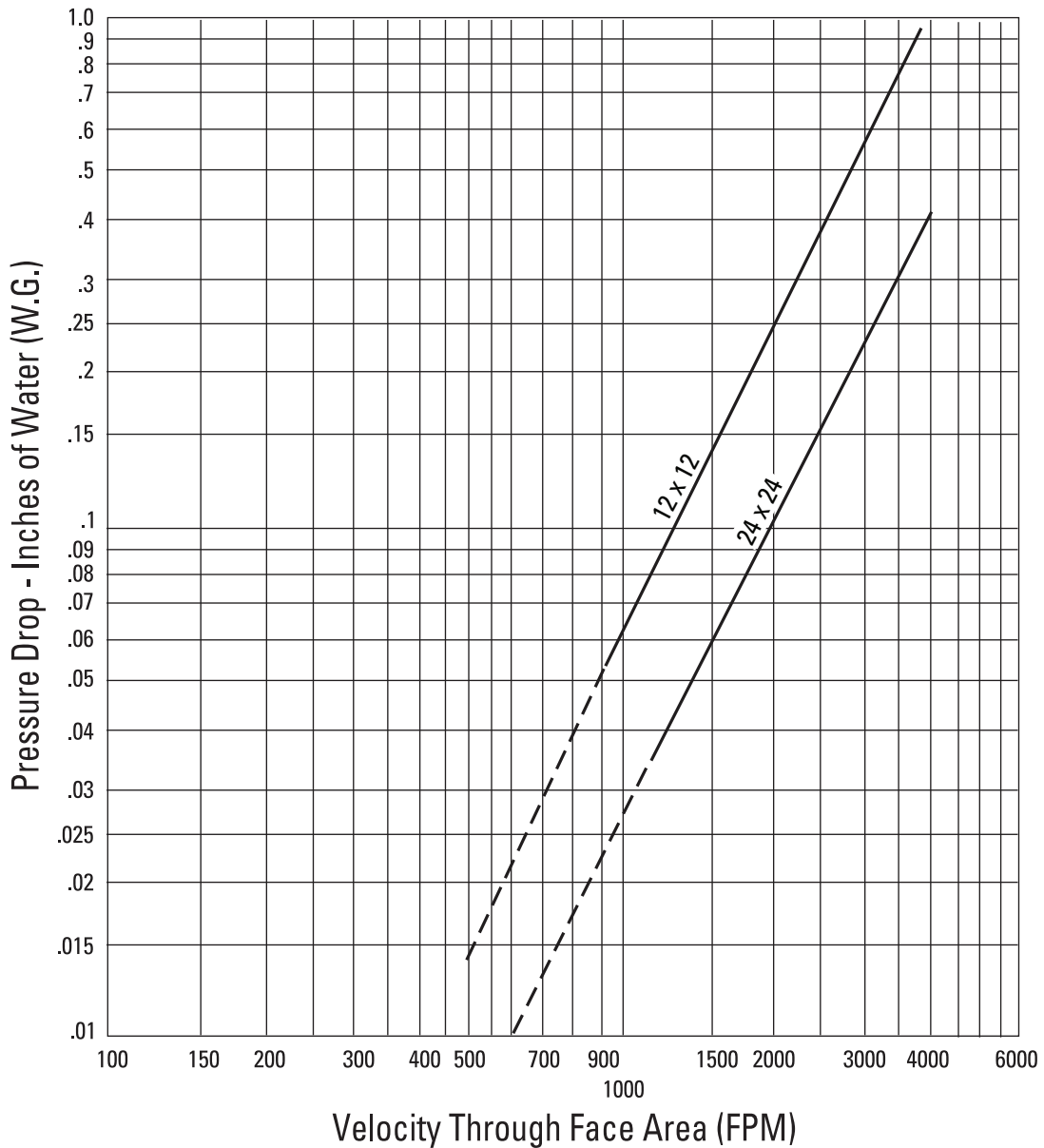

- To determine pressure drop:**
1. Locate the applicable face velocity on the bottom of the chart.
 2. Move up the chart to the most appropriate size damper line.
 3. From the intersection point, move left to determine the pressure drop.

AMCA Figure 5.3 - Ducted Inlet and Outlet

Pressure drop testing was performed by an independent laboratory to the AMCA Standard 500-D, Fig. 5.3 (ductwork upstream and downstream).

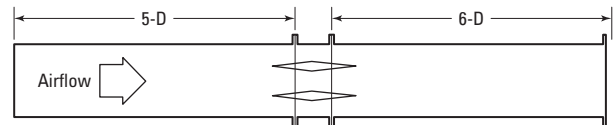

Note:

Pressure Drop data reflects damper face area only and does not take into account internally mounted quadrant.

Sleeve Requirements:

Sleeve must be installed at the factory for out of wall/floor products. As with all fire rated damper installations, the sleeve must fully penetrate the wall/floor being protected.

Sleeve length is dependent upon damper height, grille depth (including OBD) and quadrant selection:

- Standard clearance allowance for grille inset is 3" (76).
- Maximum sleeve length is 16" (406) plus the total wall depth.

Flange must be on top of barrier in horizontal installations. Damper may be optionally ordered without flange for continuous duct installation; this method requires the use of a single mounting angle for installation (see Detail).

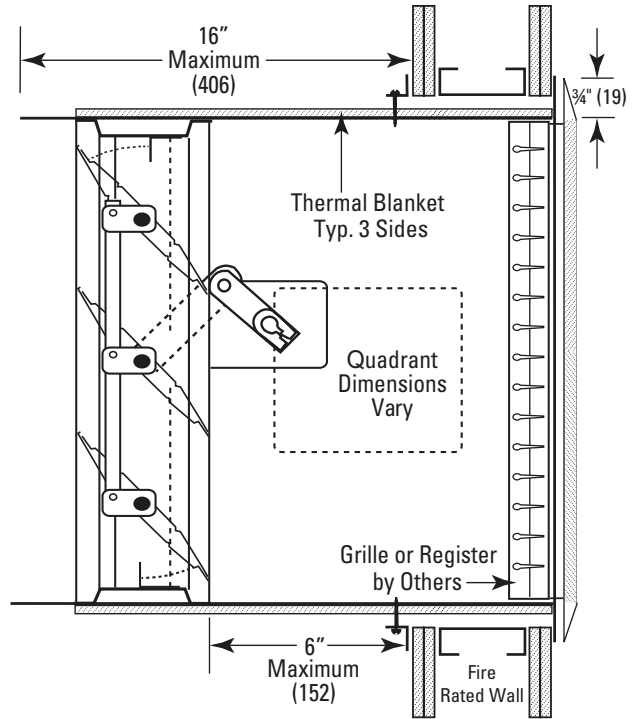

*Thermal Blanket provided 3 sides for Vertical and 4 sides for Horizontal.

Thermal Blanket:

A factory installed thermal blanket is provided on three sides (bottom excluded) for dampers ordered for vertical installation and on all four sides for dampers ordered for horizontal installation.

Due to the nature of the application for Out-of-Wall and Out-of-Floor Fire dampers, a 0.25" (6) thermal blanket is installed around the sleeve at the factory.

This insulation is required as part of the UL Listing of the out of wall/out of floor assembly and must not be removed.

