

Reference:

Client:

Project:

Consultant:

Location:

Contractor:

Date:

Submitted by:



Manufacturing Excellence

### Model SSD-AF-201

Smoke Damper  
Airfoil Blade, Class 1, UL-Classified  
(Class 1 is < 8 cfm per sq. ft. @ 4" w.g.)

### Application:

The CVS-SAFE4 model SSD-AF-201 is a Class 1 leakage rated Smoke Damper with Airfoil style blades (tested per UL 555S) for minimal pressure drop. The SSD-AF-201 has been qualified to 2,000 FPM and 4" w.g. for smoke control applications. The SSD-AF-201 is approved for vertical installation (in walls and partitions) with blades running horizontally as well as horizontal installation (floors). The SSD-AF-201 is rated for airflow and leakage in either direction.

**MAXIMUM VELOCITY\***: 2000 fpm (10.2 m/s).

**MAXIMUM PRESSURE\***: 4" wg (1kPa).

\*SSD-AF models are also approved for velocities upto 4000 fpm (20.4 m/s) at 6" w.g. (1.5 kPa) for sizes upto 36" x 36" with 20 Nm actuators.

### Standard Construction:

	Standard	Optional
<b>Frame Material</b>	20 Gauge (1) Galv. Roll-Formed Steel hat section w/ staked corners for integral bracing	-----
<b>Blade Material and Type</b>	Airfoil-shaped, double skin GI mechanically fastened to form equi. to 14-ga. (2) steel.	16 Gauge (1.5) "3V" Galv. Roll-Formed Steel
<b>Blade Sizes</b>	Min. width of 5" (127) to max. width of 7" (178)	-----
<b>Frame Depth</b>	5" (127)	-----
<b>Dimensions</b>	Actual - 1/4" (6)	Actual
<b>Axle Bearings</b>	Bronze Oilite (press fit into frame)	-----
<b>Axle Material</b>	Plated Steel	-----
<b>Linkage</b>	.125" (3.2) plated steel, Concealed in Frame	-----
<b>Sleeve</b>	16" x 20 gauge (406x1) galvanized steel	Various sleeve lengths & gauges available
<b>Operating Temp.</b>	250° (121°C)	350° (177°C)
<b>Leakage Class Rating</b>	Class 1	Class 2 (see Model SSD-AF-202)

All dimensions shown in inches, parentheses ( ) indicate millimeters.

### Minimum and Maximum Sizes:

UL 555S Rating Mounting	Minimum Size (WxH)	Maximum Size (WxH)	
		Single Section	Multiple Section
Vertical (Wall) or Horizontal (Floor)	8 x 8* (203 x 203)	36 x 48 (914 x 1219)	144 x 96 (3657 x 2438)

All dimensions shown in inches, parentheses ( ) indicate millimeters.



### LISTINGS:

UL Listing: R27700(UAE), R41135(KSA), R40068(Qatar), R41122(Egypt)

### STANDARDS MET:

NFPA Standards: 92A, 92B, 101 & 105

Building Code Standard:  
ICC International Building Code

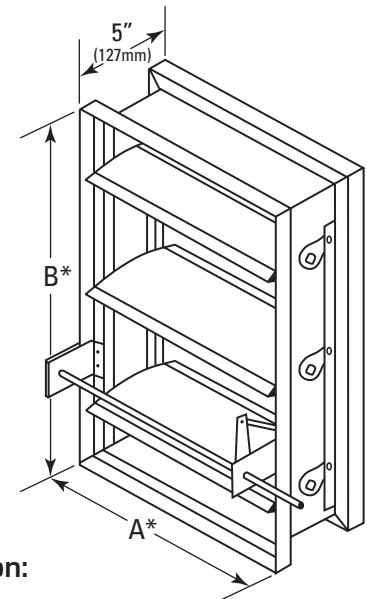

\* Width [A dimension] and Height [B dimension] are approximately 1/4" (6) undercut.

### Optional Construction:

#### Factory Sleeve:

Length: \_\_\_\_\_ (Std. 16" [406])

Gauge: 20 18 16 14 Others:.....

#### No Sleeve: Insert Type Plate

#### Framed Retaining Angles (FRA)

1-Side 2-Sides

#### Remote Control Box

RCB-1 RCB-2 RCB-3

#### Smoke Detector

Factory Mounted Shipped Loose

#### Actuators (refer to UL Damper Actuator Reference Chart)

Electric (model #): \_\_\_\_\_ Pneumatic (model #): \_\_\_\_\_

#### Actuator Location

Right External (std) Left External Internal

#### Auxiliary Switch

Add to Actuator (std.) Add to Damper (switch package)

#### Momentary Test Switch

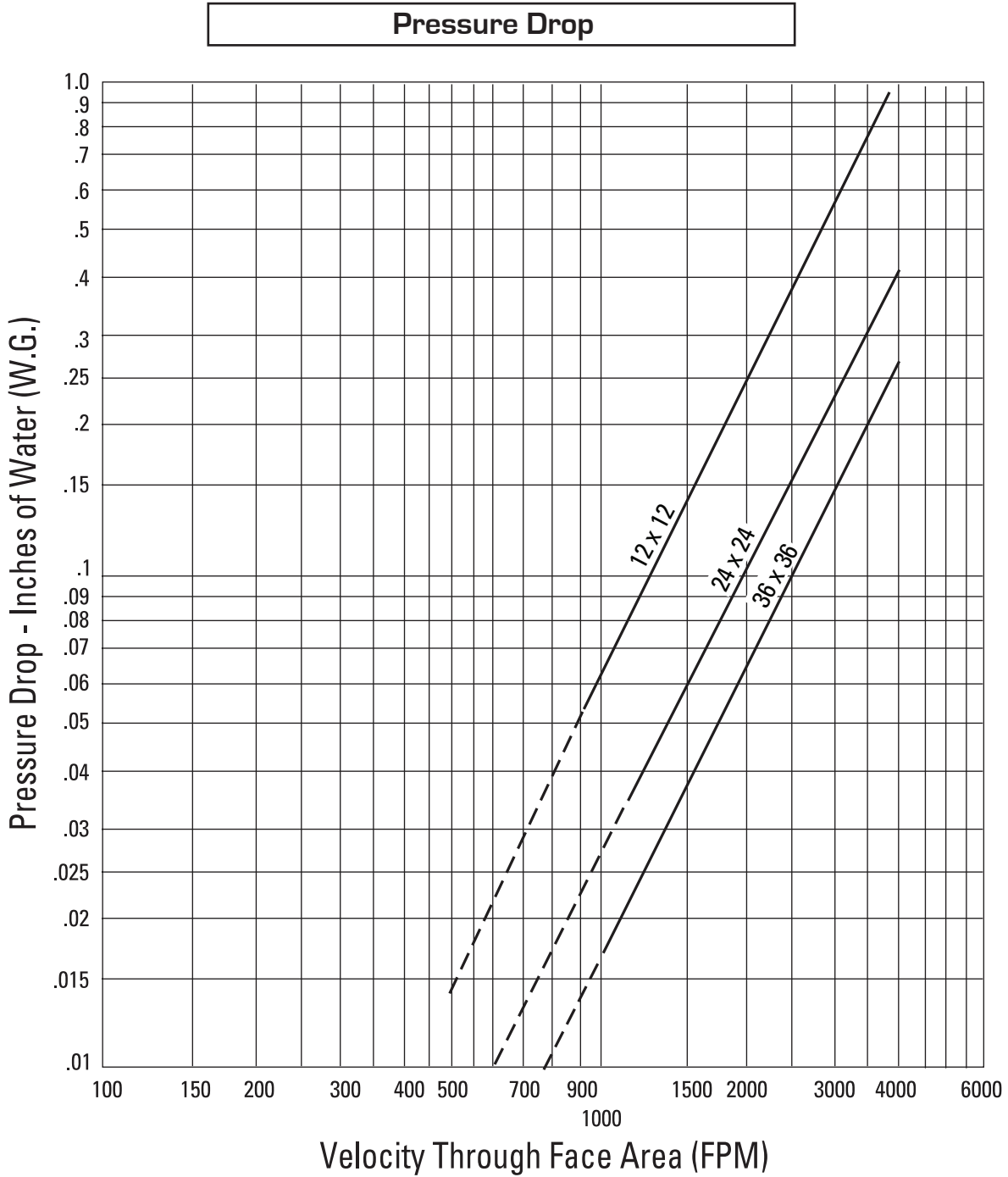

**To determine pressure drop:**

1. Locate the applicable face velocity on the bottom of the chart.
2. Move up the chart to the most appropriate size damper line.
3. From the intersection point, move left to determine the pressure drop.

**AMCA Figure 5.3 - Ducted Inlet and Outlet**

Pressure drop testing was performed by an independent laboratory to the AMCA Standard 500-D, Fig. 5.3 (ductwork upstream and downstream).

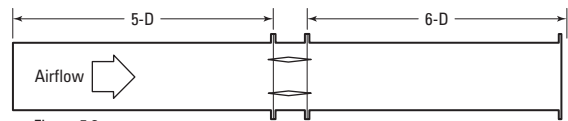

Figure 5.3

**Actuator Requirements:**

**UL555S requires that all leakage rated dampers be provided with factory mounted actuators.** Available actuators vary by damper size and velocity, pressure and temperature ratings. Consult Motor/Actuator sheet for UL Products for current offering.

**Multiple section damper assemblies may require multiple actuators.** In this case, all electric actuators will be factory wired to a single point.

If pneumatic actuators are employed, all will be plumbed to a common Valve.

As a standard, the actuator is externally installed on the lower right-hand half of the damper when viewed from the jackshaft side. **The damper may be installed/rotated 180°** such that the actuator will be located on the upper left. The top of the damper is either side of the frame as long as the blades are running parallel.

**SSD-AF-201 Notes:**

- Non-Sleeved and IT Plate dampers are furnished approximately 1/4" (6 mm) smaller than given duct dimensions.
- Sleeved dampers are furnished approx. same size as given duct dimension, unless otherwise noted.
- The SSD-AF-201 must be installed so that blades run horizontally. It is NOT recommended for blades to run vertically.
- All Smoke Dampers are supplied with a an actuator (electric or pneumatic) and are jackshafted.

**Applicable CVS Literature:**

- Smoke Damper Installation, Operation and Maintenance (IOM)
- Optional Sealing of Dampers in Fire and Smoke Rated Walls or Floors
- Installing the Smoke Detector
- Field Modification of Factory Supplied Sleeves

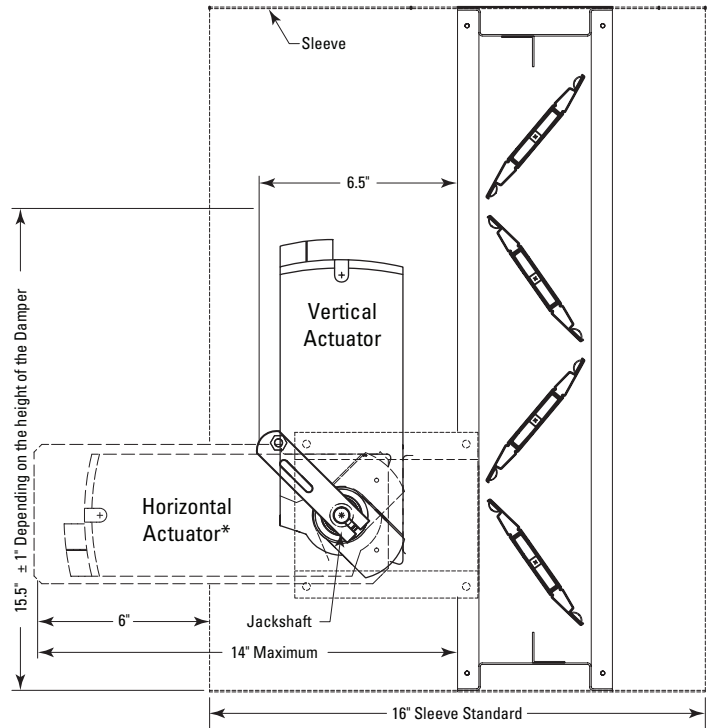

\*Horizontal Actuators can be provided as "low profile" option and will be provided on a standoff to allow for duct connections.

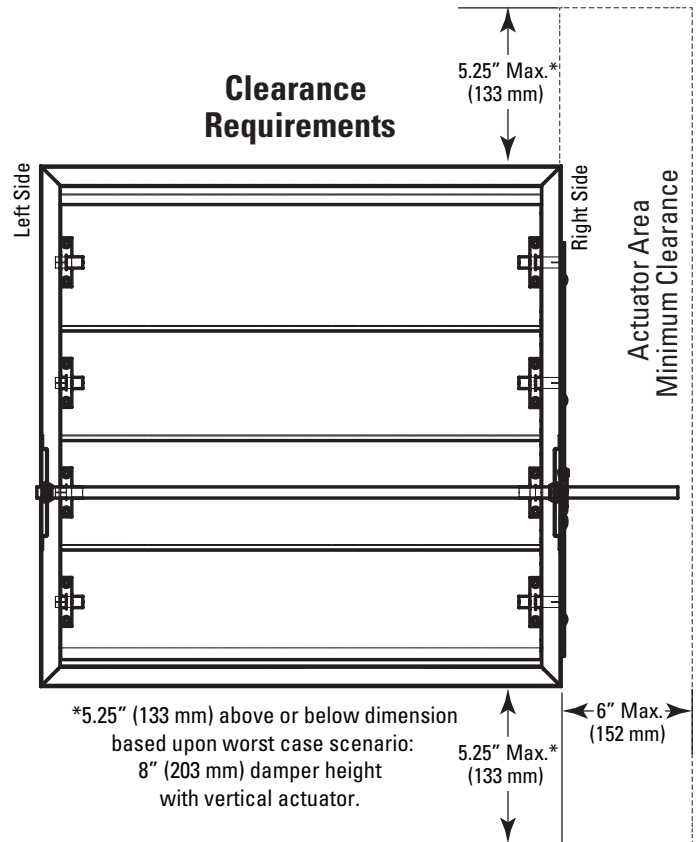

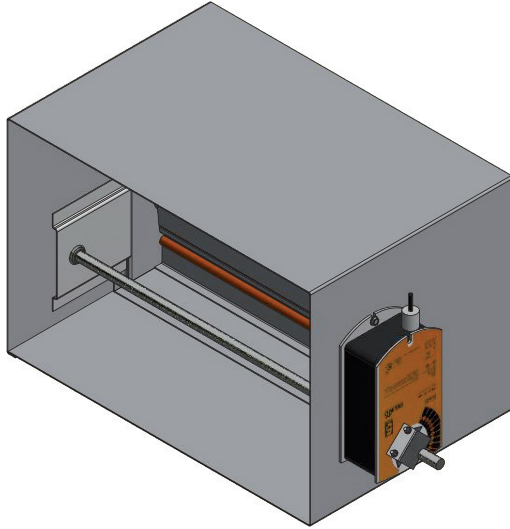

Standard Sleeve configuration where sleeve is added to damper. Damper size will be 1/4" (6) under ordered dimensions; sleeve dimension will be roughly ordered dimensions.

**Flanges:** An optional 3/4" (19) flanged sleeve is available for grille mounting.

**Note:** If actuator is to be externally mounted, the flange(s) will need to be field installed.

**Duct Connections/Sleeve Transitions:**

Minimum Damper height is 8" (203). If smaller duct heights are required, transition will be supplied as shown in the detail SSD-AF-201.

- **Minimum duct height is 6" (152)**

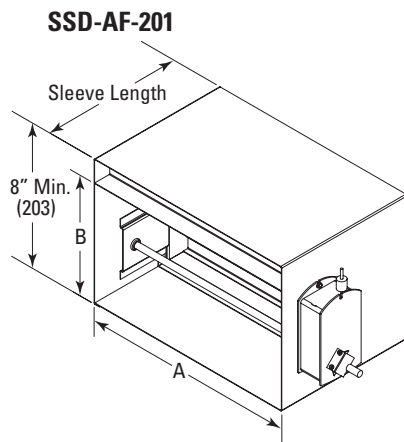

Square to Round transitions attached on both ends of the damper sleeve (Model SSD-AF-201). Product is ordered on duct Diameter; damper will be fabricated 2" (51) larger in width and height. Collar extends 1.25" (32) beyond the sleeve length.

- **Minimum 6" (152) diameter, Maximum 94" (2388) diameter for Vertical or Horizontal mount.**

**A = Duct Width**  
**B = Duct Height**

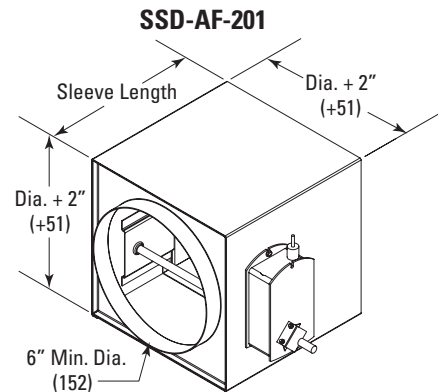

Rectangular to Oval (Model SSD-AF-201) or Square/Rectangular to Square/Rectangular (Model SSD-AF-201) transitions attached on both ends of the damper sleeve. Product is ordered on width and height of duct connection required; damper will be fabricated 2" (51) larger in width and height. Collar extends 1.25" (32) beyond the sleeve length.

- **Minimum 6" w x 6" h (152 x 152), Maximum 142" w x 94" h (3607 x 2388) for Vertical or Horizontal mount.**

